



# Cambridge International AS & A Level

DESIGN & TECHNOLOGY

9705/12

Paper 1

October/November 2022

3 hours



You must answer on the answer booklet/paper.

You will need: Answer booklet/A4 paper                      Coloured pencils  
A3 drawing paper (2 sheets)                      Extra sheets of A3 drawing paper if needed  
A range of design drawing equipment

## INSTRUCTIONS

- Answer **three** questions in total:
  - Section A: answer **one** question on the answer booklet/A4 paper provided.
  - Section B: answer **one** question on the answer booklet/A4 paper provided.
  - Section C: answer **one** question on A3 drawing paper. Use both sides of the paper.
- You may request additional sheets of A3 drawing paper, but only if you have used up both sides of each of the 2 sheets provided.
- If you have been given an answer booklet, follow the instructions on the front cover of the answer booklet.
- Use a black or dark blue pen.
- Write your name, centre number and candidate number on all the work you hand in.
- Do **not** use an erasable pen or correction fluid.
- You may use an HB pencil, or coloured pencils as appropriate, for any diagrams, graphs or rough working.
- At the end of the examination, fasten all your work together. Do **not** use staples, paper clips or glue.

## INFORMATION

- The total mark for this paper is 120.
- The number of marks for each question or part question is shown in brackets [ ].
- All dimensions are in millimetres.

This document has **12** pages. Any blank pages are indicated.

## Section A

Answer **one** question from this section on the Answer Booklet/A4 paper provided.

- 1 Fig. 1.1 gives details of a drawer which is to be made in a school workshop.

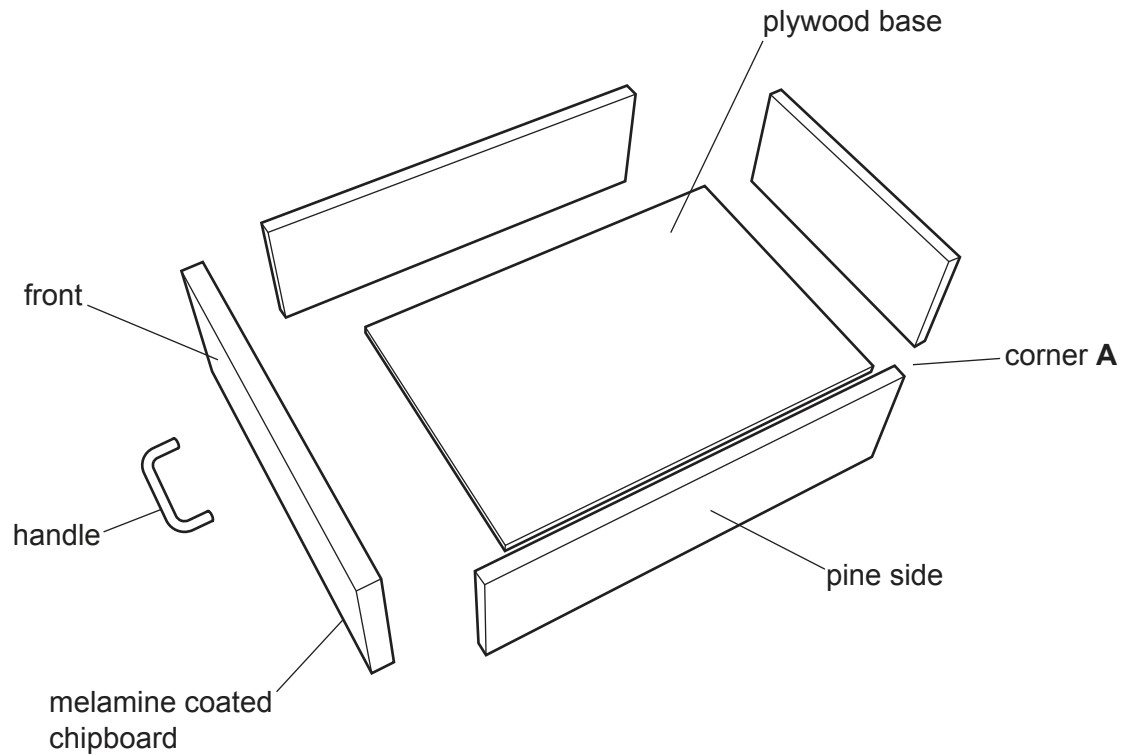

**Fig. 1.1**

- (a) State **two** reasons why the drawer front is made from melamine coated chipboard. [2]
- (b) Use notes and sketches to describe:
- (i) how a knock down (KD) fitting could be used to join corner **A** [6]
  - (ii) a method of joining the plywood base to the sides. [6]
- You must give details about the tools, equipment and processes involved and the safety precautions that have to be undertaken at each stage.
- (c) Use notes and sketches to show a temporary method of attaching the handle to the front of the drawer. [6]

2 Fig. 2.1 gives details of a stencil set which is to be made in a school workshop.

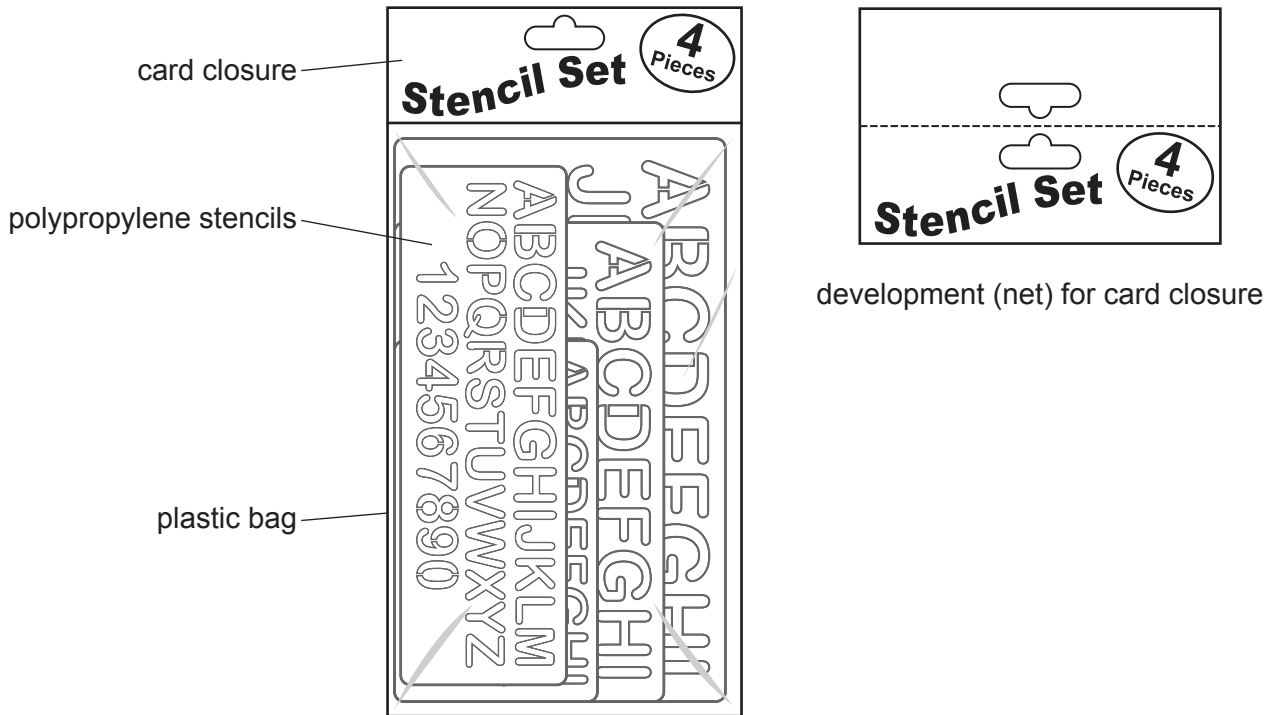
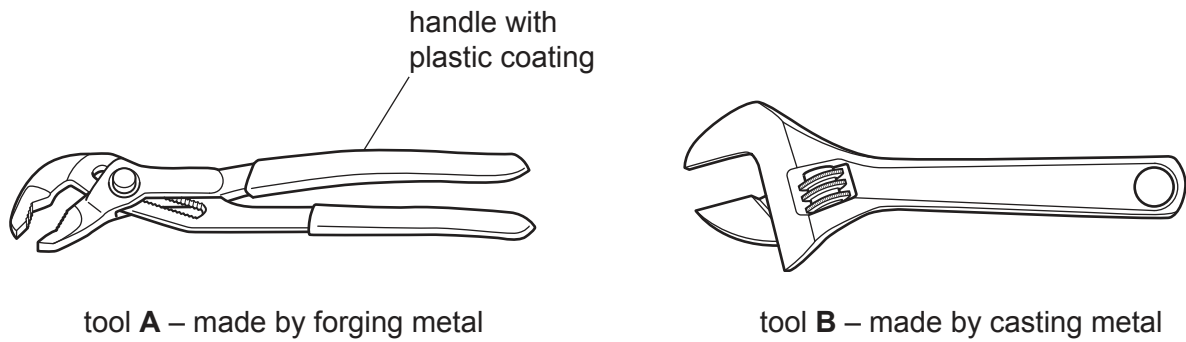

Fig. 2.1

- (a) Explain why polypropylene is a suitable material for the stencils. [2]
- (b) Use notes and sketches to describe:
- how to mark out and cut out the development (net) for the card closure [6]
  - a method of joining the card closure to the plastic bag, so that it can be opened and closed. [6]
- You must give details about the tools, equipment and processes involved and the safety precautions that have to be undertaken at each stage.
- (c) Use notes and sketches to show a method of reproducing the text on 1000 copies of the card closure. [6]

3 Fig. 3.1 gives details of two adjustable tools which are used in a school workshop.



**Fig. 3.1**

(a) State **two** reasons why the handle of tool **A** has a plastic coating. [2]

(b) Use notes and sketches to describe **one** of the following processes:

- forging metal

or

- casting metal.

[6]

You must give details about the tools, equipment and processes involved and the safety precautions that have to be undertaken at each stage.

(c) Use notes and sketches to describe:

(i) the mechanism that makes tool **A** adjustable [6]

(ii) the mechanism that makes tool **B** adjustable. [6]

## Section B

Answer **one** question from this section on the Answer Booklet/A4 paper provided.

- 4 Fig. 4.1 gives details of an incomplete wheelbarrow that is used for moving garden rubbish.

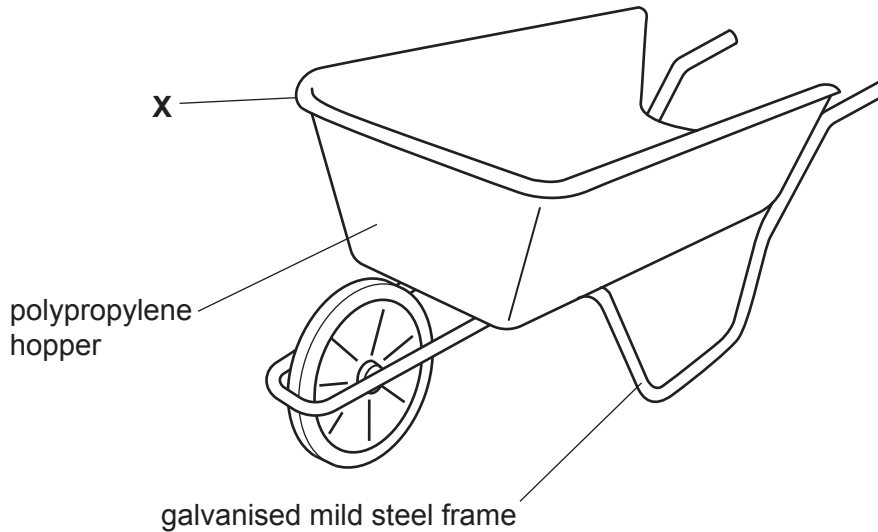

**Fig. 4.1**

- (a) Explain the function of the design feature shown at **X**, the rim on the polypropylene hopper. [2]
- (b) Identify and describe **two** problems with the wheelbarrow. [4]
- (c) Use notes and sketches to explain how the wheelbarrow would need to be changed to overcome the **two** problems you have identified in **part (b)**. [6]
- (d) Discuss why manufacturers of gardening equipment, such as the wheelbarrow, compare materials through the use of destructive testing. Your answer should:
- (i) analyse the given situation and identify **three** relevant issues raised by the question [3]
  - (ii) explain why you consider these issues to be relevant [3]
  - (iii) contain specific examples/evidence to support your conclusions. [2]

5 Fig. 5.1 gives details of an incomplete portable display stand used by a sportswear company.

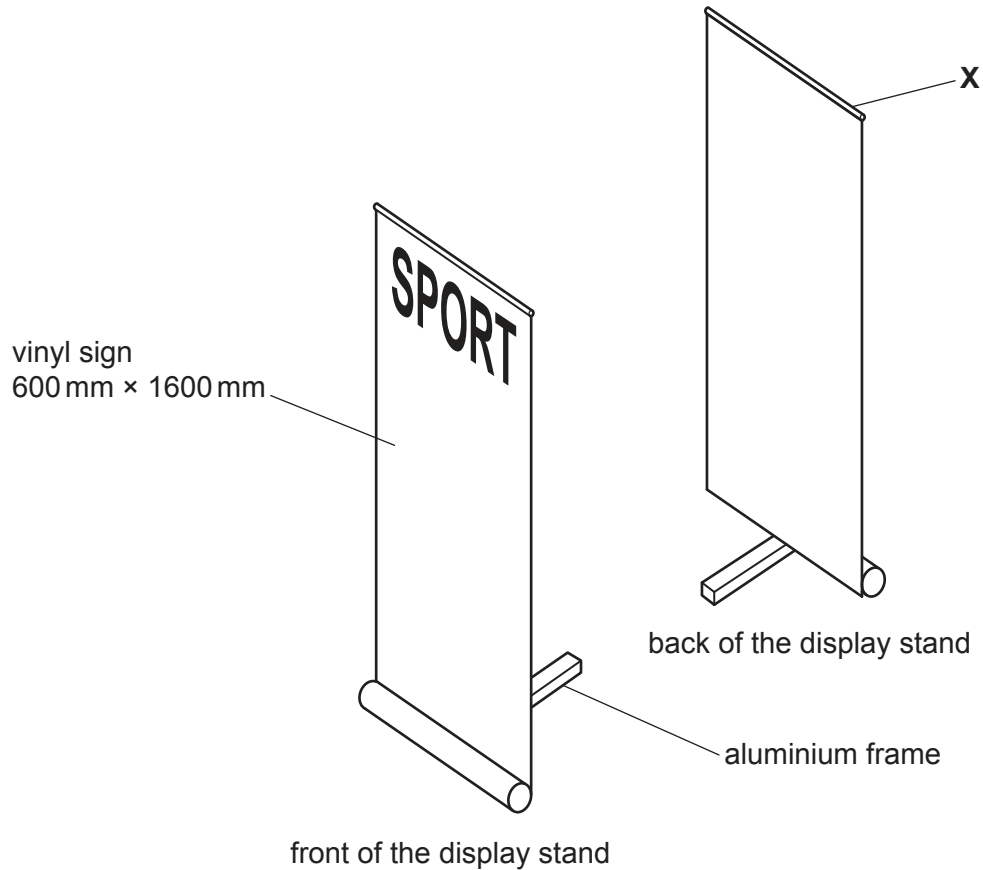

**Fig. 5.1**

- (a) Explain the function of the design feature shown at **X**, the metal top rail. [2]
- (b) Identify and describe **two** problems with the display stand. [4]
- (c) Use notes and sketches to explain how the display stand would need to be changed to overcome the **two** problems you have identified in **part (b)**. [6]
- (d) Discuss why designers of products, such as the display stand, should consider the positive and negative effects of advertising on society. Your answer should:
- (i) analyse the given situation and identify **three** relevant issues raised by the question [3]
  - (ii) explain why you consider these issues to be relevant [3]
  - (iii) contain specific examples/evidence to support your conclusions. [2]

6 Fig. 6.1 gives details of an incomplete electric fan.

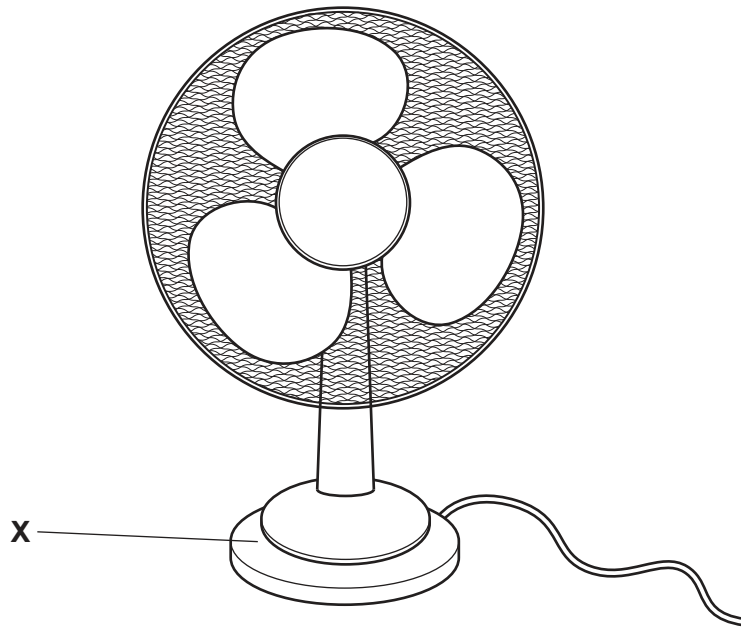

**Fig. 6.1**

- (a) Explain the function of the design feature shown at **X**. [2]
- (b) Identify and describe **two** problems with the electric fan. [4]
- (c) Use notes and sketches to explain how the electric fan would need to be changed to overcome the **two** problems you have identified in **part (b)**. [6]
- (d) Discuss why many electrical products, such as the fan, are designed with built-in obsolescence. Your answer should:
- (i) analyse the given situation and identify **three** relevant issues raised by the question [3]
  - (ii) explain why you consider these issues to be relevant [3]
  - (iii) contain specific examples/evidence to support your conclusions. [2]

## Section C

Answer **one** question from this section on the plain A3 paper provided.

You are provided with two sheets of plain A3 paper. You should use **both** sides of the paper. **Each** of the four parts (a) – (d) of the question you choose to answer should take up one side of paper.

When you are asked to **develop** a design you must show, using notes and sketches, the development and evaluation of a **range** of ideas into a single design solution. The design proposal should be annotated to give details about materials, joining methods and important sizes.

7 Fig. 7.1 shows information required to design a spice jar holder.

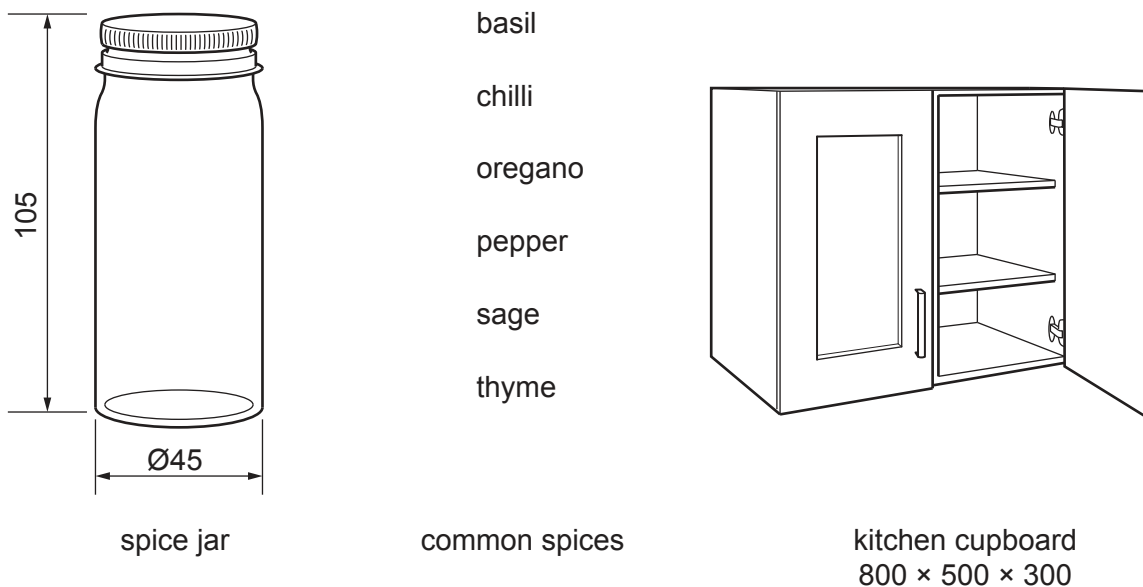
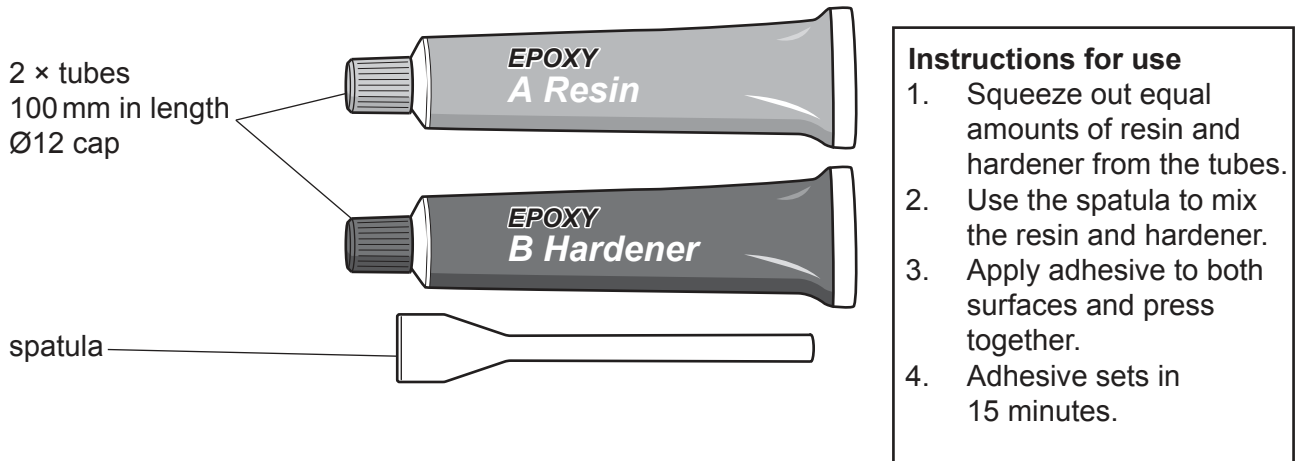

Fig. 7.1

- (a) Use notes and sketches to **develop** a design for a spice jar holder that will hold six spice jars of the size shown in Fig. 7.1. [20]
- (b) Use notes and sketches to **develop** a design for a method of allowing a visually impaired person to identify the spice in each jar. [20]
- (c) Use notes and sketches to **develop** a design for a height adjustable fixing that will allow the spice holder designed in **part (a)** to be mounted on the inside of a kitchen cupboard door. [20]
- (d) Produce a pictorial (3D) rendered drawing of the spice holder mounted on a door which shows all of the features that you have designed in **parts (a) – (c)**. [20]



8 Fig. 8.1 shows the three components of an adhesive pack and the instructions for use.



**Fig. 8.1**

- (a) Use notes and sketches to **develop** a design for an instruction leaflet to show how to use the adhesive. The leaflet should only use pictures and **not** words. [20]
- (b) Use notes and sketches to **develop** a design for an environmentally friendly package for the three components of the adhesive pack and the instruction leaflet designed in **part (a)**. [20]
- (c) Use notes and sketches to **develop** a design for a brand name and colour scheme for the adhesive and the package designed in **part (b)**. [20]
- (d) Produce a pictorial (3D) rendered drawing of the complete package for the adhesive which shows all of the features that you have designed in **parts (a) – (c)**. [20]

- 9 Fig. 9.1 shows an outdoor chair that hangs by a rope from a frame.

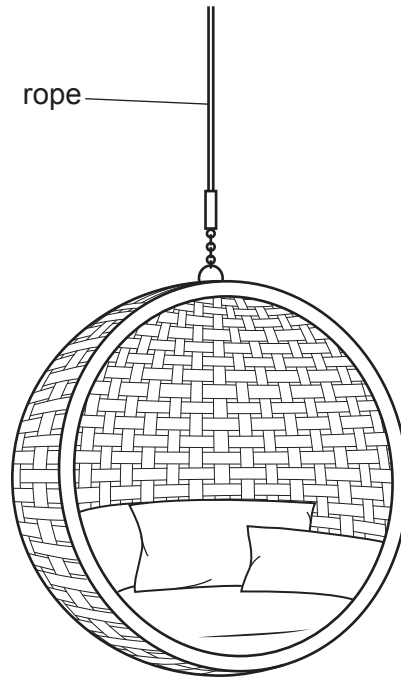

**Fig. 9.1**

- (a) Use notes and sketches to **develop** a design for a freestanding frame that will allow the chair to swing from the rope. [20]
- (b) Use notes and sketches to **develop** a design for a temporary method of fixing the frame designed in **part (a)** to the ground so that it can easily be moved to a new position. [20]
- (c) Use notes and sketches to **develop** a design for a device that will attach to the frame designed in **part (a)** to allow the height of the chair to be adjusted. [20]
- (d) Produce a pictorial (3D) rendered drawing of the complete frame which shows all of the features that you have designed in **parts (a) – (c)**. [20]



**BLANK PAGE**

---

Permission to reproduce items where third-party owned material protected by copyright is included has been sought and cleared where possible. Every reasonable effort has been made by the publisher (UCLES) to trace copyright holders, but if any items requiring clearance have unwittingly been included, the publisher will be pleased to make amends at the earliest possible opportunity.

To avoid the issue of disclosure of answer-related information to candidates, all copyright acknowledgements are reproduced online in the Cambridge Assessment International Education Copyright Acknowledgements Booklet. This is produced for each series of examinations and is freely available to download at [www.cambridgeinternational.org](http://www.cambridgeinternational.org) after the live examination series.

Cambridge Assessment International Education is part of Cambridge Assessment. Cambridge Assessment is the brand name of the University of Cambridge Local Examinations Syndicate (UCLES), which is a department of the University of Cambridge.